



Q-Tec™ QWS Series High Efficiency Geothermal/Water Source Packaged Step-Capacity Heat Pump — R-410A

2 to 5 Ton 2-Stage Compressors Extended Range Operation: 25° to 110°F EWT

The Q-Tec™ Series self contained packaged water-to-air heat pump is designed to be installed inside a building structure against an exterior exposed wall when ventilation option is selected. When no ventilation option is used, the QWS Series units can be installed in any interior space accessible to water supply system and condensate drain.

Q-Tec's™ design provides "whisper" quiet operation with total comfort for the occupants at high efficiency levels and eliminates the need for roof-mounted equipment and outside condensing units and can meet your specific architectural requirements.

Q-Tec's™ "quiet technology" provides extremely low indoor sound levels by using special components and materials in the construction of the unit. By using special motors and sound insulation we have built a heat pump system that is significantly quieter than competitive product available today.

Q-Tec™ is suitable for both new construction and renovation projects for schools, modular buildings and light commercial buildings. A variety of ventilation options are designed to address your project's indoor air quality.

The Q-Tec™ Series unique design allows all maintenance and service to be performed inside the building to facilitate multi-story installations. Access to air filters and controls is accomplished through a hinged front panel for easy accessibility. All Q-Tec™ Series models are built on heavy duty permanent rollers for easy installation and removal.

Product Features

Step Capacity Compressor

Copeland step capacity (2-stage) scroll compressors are designed for increased efficiency, quieter operation and improved reliability for longer life.

Reduced Sound Level

Compressor sound cover and double isolation grommets reduce sound levels.

R-410A Refrigerant

Designed with R-410A (HFC) non-ozone depleting refrigerant in compliance with the Montreal protocol and 2010 EPA requirements.

Liquid Line Filter Drier

Standard on all models.

Phase Rotation Monitor

Standard on all 3 phase scroll compressors. Protects against reverse rotation if power supply is not properly connected.

Indoor Blower System

All models feature a variable speed (ECM) motor providing super high efficiency, low sound levels and soft start capabilities. The motor is self adjusting to provide the proper airflow rate at high static pressure for ducted installations without user adjustment or wiring changes. Dual blower usually for quiet operation.

High Efficiency Coaxial Water Coil

Fully insulated to minimize sweating. Copper or cupro-nickel coils available.

Double O-Ring Water Connections

Positive water-tight connections with built-in union.

Pumping System

Unit can be connected to central piping/pumping system from well field, boiler/tower or optional pump module can be installed inside unit for individual earth loop applications.

Copper Tube/Aluminum Fin Evaporator Coil

Grooved copper tubing and enhanced aluminum fins provide maximum heat transfer and high energy efficiency. Evaporator coil constructed with hydrophilic fin stock that seals fin surface against aluminum oxide formation, is resistant to mold and mildew growth (tested to ASTM D3273, no growth) and reduces beading of condensate on the fin surface.

Cabinet

Constructed of 20 gauge pre-painted or vinyl laminated galvanized steel. Choice of either two tone vinyl finish with "slate" front panels and "platinum" cabinet for designer appearance, or painted steel. Vinyl finish is very resistant to scratching and marring and is very easy to clean. Tamper resistant fasteners are provided for access panels. Unit includes built-in rollers for easy installation into wall sleeve and removal for service if necessary. Hinged, lockable front panel for filter service and access to primary functional electrical controls.

Insulation

Cabinet is fully insulated with foil covered, high density fiberglass insulation with sealed edge treatment and special sound deadening insulation material in the compressor section. All insulation is designed to resist mold and mildew growth and facilitate ease of cleaning.



Electrical Components

Are easily accessible for routine inspection and maintenance through front service panels. Circuit breaker standard on all 208/230V models and rotary disconnect standard on all 460V models. Circuit breaker/toggle disconnect access is through lockable access panel. Lock and key provided as standard equipment.

Hot Water Coil

A plenum mounted hot water coil is available for both free-blow and ducted applications.

Air Filter

Two-inch pleated MERV6 filter is standard.

Compressor Control Module

Built-in off-delay timer adjustable from 30 seconds to 5 minutes. Two-minute on-delay if power interrupt. 120-second bypass for low pressure control, and both soft and manual lockouts for high and low pressure controls.

High Pressure Switch

Protects refrigerant circuit against excessively high pressure.

Low Pressure Switch

Provides loss of charge protection plus protects against freeze-up of coaxial coil during heating mode due to water flow or temperature problems. Two switches are installed, and the factory wired switch is for fresh water applications.

Diagnostic Light

System service - indicates high or low pressure switch operation for compressor protection. Located in inside control panel.

Stainless Steel Drain Pan

Provides extended life of the evaporator drain pan for maximum corrosion resistance.

Side Trim Piece Extension – Optional

Trim kits available for covering the space between unit and wall for spaces from 4" to 12".

Optional Ventilation Packages

Optional energy recovery ventilator can provide up to 450 cfm of outside air and exhaust through the unit while maintaining indoor comfort and humidity levels. Other available options include commercial room ventilator with exhaust, and barometric damper without exhaust. Outside wall and ventilation sleeve are required for installations with ventilation option.

Optional Ventilation Wall Sleeve

Required for ventilation options only. Constructed of 16 gauge galvanized steel, coated with epoxy primer and a baked on polyester enamel paint, which allows it to withstand 1000 hours of salt spray tests per ASTM B117-03. Ordered separately.

Specifications - 2 and 3 Ton						
MODELS	QW2S1-A	QW2S1-B	QW2S1-C	QW3S1-A	QW3S1-B	QW3S1-C
ELECTRICAL RATING--60 HZ	230/208 - 1	230/208 - 3	460 - 3	230/208 - 1	230/208 - 3	460 - 3
Operating Voltage Range	197-253		414-506	197-253		414-506
COMPRESSOR-- CIRCUIT A						
Voltage	230/208		460	230/208		460
Rated Load Amps	10.2/10.9	6.3/6.8	3.5	14.9/17.5	10.0/11.7	4.0
Branch Circuit Selection Current	10.9	6.8	3.5	17.5	11.7	4.5
Lock Rotor Amps	52	63	30	82	58	29
MOTOR & EVAPORATOR						
Blower Motor HP/SPD	1/3 / Variable			1/2 / Variable		
Blower Motor--Amps	2.4			3.1		
Filter Sizes (inches) STD.	1 - 16x20x2 & 1 - 16x16x2			1 - 16x20x2 & 1 - 16x16x2		
SHIPPING WEIGHT--LBS.	535 lb.			535 lb.		

Specifications - 4 and 5 Ton						
MODELS	QW4S1-A	QW4S1-B	QW4S1-C	QW5S1-A	QW5S1-B	QW5S1-C
ELECTRICAL RATING--60 HZ	230/208 - 1	230/208 - 3	460 - 3	230/208 - 1	230/208 - 3	460 - 3
Operating Voltage Range	197-253		414-506	197-253		414-506
COMPRESSOR-- CIRCUIT A						
Voltage	230/208		460	230/208		460
Rated Load Amps	13.5/15.2	11.2/12.6	4.1	23.5/27.4	16.2/18.9	8.3
Branch Circuit Selection Current	21.1	17.6	6.4	27.4	18.9	9.0
Lock Rotor Amps	96	123	41	118	123	62
MOTOR & EVAPORATOR						
Blower Motor HP/SPD	3/4 / Variable			3/4 / Variable		
Blower Motor--Amps	3.6			4.0		
Filter Sizes (inches) STD.	1 - 16x20 & 1 - 16x16			1 - 16x20 & 1 - 16x16		
SHIPPING WEIGHT--LBS.	625 lb.			625 lb.		

See Page 9 for Electrical Specifications

Indoor Blower Performance – CFM (0.00" through 0.50" H₂O) ①						
Model	Rated ESP.	Max. ESP ①	Blower Only	1st Stage	2nd Stage De-Rated ②	2nd Stage
QW2S1	0.10	0.5	800	800	900	1000
QW3S1	0.15	0.5	800	900	1050	1150
QW4S1	0.15	0.5	900	1150	1225	1350
QW5S1	0.15	0.5	900	1250	1300	1450

- ① These systems contain variable speed (ECM) motor which maintains airflow across static range. Filters deeper than 2" will reduce the amount of available static for duct design.
- ② Removal of a jumper wire internal of the control panel will allow reduced CFM for quieter operation.



• Intertek ETL Listed to Standard for Safety Heating and Cooling Equipment ANSI/UL 1995/CSA 22.2 No. 236-05, Third Edition.

ISO 13256-1 Performance Data ①

Ground Loop Heat Pump Tested & Certified to ISO 13256-1:1998							
MODEL	System Capacity Modulation	Fluid Flow Rate GPM	Airflow CFM	Cooling Brine Full Load 77°F Part Load 68°F		Heating Brine Full Load 32°F Part Load 41°F	
				Capacity BTUH	EER BTU/W	Capacity BTUH	COP
				QW2S	Full Part	7	1000 800
QW3S	Full Part	8	1150 900	35,400 26,200	16.2 22.6	28,400 22,000	3.6 4.0
QW4S	Full Part	9	1350 1150	49,500 37,000	16.5 22.2	34,500 28,500	3.4 3.7
QW5S	Full Part	11	1450 1250	56,000 44,500	15.5 20.9	45,000 37,000	3.2 3.6

Water Loop Heat Pump Tested & Certified to ISO 13256-1:1998							
MODEL	System Capacity Modulation	Fluid Flow Rate GPM	Airflow CFM	Cooling — EWT 86°F		Heating — EWT 68°F	
				Capacity BTUH	EER BTU/W	Capacity BTUH	COP
				QW2S	Full Part	6.1	1000 800
QW3S	Full Part	8.6	1150 900	34,000 23,600	14.3 16.2	41,800 30,400	4.4 5.1
QW4S	Full Part	11.3	1350 1150	45,000 33,000	14.5 16.1	44,000 33,000	3.9 4.4
QW5S	Full Part	13.7	1450 1250	53,500 40,500	13.8 15.1	65,500 48,500	3.9 4.3

① ISO Standard 13256-1:1998, "Water to Air and Brine to Air Heat Pumps", which includes watt allowance for water pumping. Cooling capacity based on 80.6°F DB, 66.2°F WB entering air temperature. Heating capacity based on 68°F DB entering air temperature.

All 1-phase models meet the minimum efficiency requirements of the Energy Star (ES) efficiency program for Ground Loop applications. Currently, there is no ES efficiency program for 3-phase equipment or for Water Loop applications.

Correction Factors @ Increased Water Flows

Rated Flow Plus	Cooling		Heating	
	BtuH	Watts	BtuH	Watts
2 GPM	1.005	0.988	1.006	1.002
3 GPM	1.007	0.984	1.009	1.003
4 GPM	1.008	0.979	1.011	1.003

QW2S1

Full Load Capacities based upon rated flow of 7 GPM of 15% methanol/mass at 1000 CFM airflow.

COOLING FULL LOAD

Entering Fluid Temp. (°F)	Entering Air Temp. (°F)	Total Capacity (MBtuH)	Sensible Capacity (MBtuH)	Sensible to Total Ratio	Power Input (KW)	Heat of Rejection (MBtuH)	EER
50°	70° DB 59° WB	25.2	19.1	0.75	1.02	28.3	21.1
60°		24.2	18.8	0.77	1.20	27.9	19.0
70°		23.3	18.4	0.79	1.37	27.5	16.9
80°		22.3	18.1	0.81	1.55	27.0	14.9
90°		21.4	17.8	0.83	1.73	26.6	12.8
100°		20.4	17.4	0.85	1.91	26.1	10.7
110°		19.5	17.1	0.87	2.08	25.7	8.6
50°	75° DB 63° WB	27.1	19.8	0.72	1.04	30.4	22.4
60°		26.1	19.5	0.74	1.21	30.0	20.2
70°		25.1	19.2	0.77	1.39	29.5	18.0
80°		24.0	18.9	0.79	1.57	29.1	15.8
90°		23.0	18.5	0.81	1.75	28.6	13.6
100°		22.0	18.2	0.83	1.92	28.2	11.5
110°		21.0	17.9	0.85	2.10	27.7	9.3
50°	80° DB 67° WB	29.0	20.5	0.70	1.06	32.6	23.7
60°		28.0	20.2	0.72	1.23	32.2	21.4
70°		26.9	19.9	0.74	1.41	31.7	19.1
80°		25.8	19.6	0.76	1.59	31.2	16.8
90°		24.8	19.3	0.78	1.76	30.8	14.5
100°		23.7	19.0	0.80	1.94	30.3	12.2
110°		22.6	18.7	0.82	2.12	29.9	9.9
50°	85° DB 71° WB	31.1	21.2	0.67	1.08	34.9	24.9
60°		30.0	20.9	0.69	1.25	34.5	22.5
70°		28.8	20.6	0.71	1.43	34.0	20.1
80°		27.7	20.3	0.73	1.61	33.5	17.8
90°		26.6	20.0	0.76	1.78	33.0	15.4
100°		25.4	19.7	0.78	1.96	32.6	13.0
110°		24.3	19.5	0.80	2.14	32.1	10.6

HEATING FULL LOAD

Entering Fluid Temp. (°F)	Entering Air Temp. (°F)	Total Capacity (MBtuH)	Leaving Air Temp. (°F)	Power Input (KW)	Heat of Absorption (MBtuH)	COP
25°	65°	19.0	82.5	1.51	13.6	3.7
30°		20.3	83.8	1.54	14.8	3.9
40°		22.9	86.2	1.60	17.2	4.2
50°		25.5	88.6	1.67	19.6	4.5
60°		28.8	91.7	1.76	22.7	4.8
70°		32.1	94.7	1.84	25.7	5.1
80°		35.4	97.8	1.93	28.7	5.4
25°	70°	18.5	87.2	1.55	13.2	3.5
30°		19.8	88.3	1.58	14.4	3.7
40°		22.4	90.7	1.65	16.7	4.0
50°		24.9	93.1	1.72	19.0	4.25
60°		28.2	96.1	1.80	22.0	4.6
70°		31.4	99.1	1.89	24.9	4.9
80°		34.7	102.1	1.98	27.9	5.2
25°	75°	18.7	92.3	1.74	12.9	3.2
30°		20.0	93.5	1.77	14.0	3.3
40°		22.6	95.9	1.85	16.2	3.6
50°		25.2	98.3	1.93	18.5	3.8
60°		28.5	101.4	2.02	21.3	4.1
70°		31.7	104.4	2.12	24.2	4.4
80°		35.0	107.4	2.22	27.1	4.7

Full Load Capacities based upon rated flow of 7 GPM of 15% methanol/mass at 800 CFM airflow.

COOLING PART LOAD

Entering Fluid Temp. (°F)	Entering Air Temp. (°F)	Total Capacity (MBtuH)	Sensible Capacity (MBtuH)	Sensible to Total Ratio	Power Input (KW)	Heat of Rejection (MBtuH)	EER
50°	70° DB 59° WB	20.0	16.1	0.79	0.58	21.8	27.0
60°		19.0	15.7	0.82	0.72	21.2	23.9
70°		17.9	15.2	0.85	0.86	20.5	20.8
80°		16.9	14.7	0.87	1.00	19.9	17.8
90°		15.9	14.2	0.90	1.14	19.3	14.7
100°		14.8	13.8	0.93	1.28	18.6	11.6
110°		13.8	13.3	0.95	1.42	18.0	8.5
50°	75° DB 63° WB	21.5	16.7	0.77	0.59	23.4	28.6
60°		20.4	16.3	0.79	0.73	22.7	25.4
70°		19.3	15.8	0.82	0.87	22.1	22.1
80°		18.2	15.3	0.85	1.01	21.4	18.9
90°		17.1	14.9	0.87	1.15	20.8	15.7
100°		16.0	14.4	0.90	1.29	20.1	12.4
110°		14.9	13.9	0.93	1.43	19.4	9.2
50°	80° DB 67° WB	23.0	17.3	0.74	0.60	25.1	30.3
60°		21.9	16.9	0.77	0.74	24.4	26.9
70°		20.7	16.4	0.79	0.88	23.7	23.5
80°		19.5	15.9	0.82	1.02	23.0	20.1
90°		18.4	15.5	0.85	1.16	22.3	16.6
100°		17.2	15.0	0.87	1.30	21.6	13.2
110°		16.0	14.5	0.90	1.44	20.9	9.8
50°	85° DB 71° WB	24.7	17.9	0.71	0.62	26.9	31.9
60°		23.4	17.4	0.74	0.76	26.1	28.4
70°		22.2	17.0	0.77	0.89	25.4	24.8
80°		20.9	16.5	0.79	1.03	24.7	21.2
90°		19.7	16.1	0.82	1.17	24.0	17.6
100°		18.5	15.6	0.84	1.31	23.2	14.1
110°		17.2	15.1	0.87	1.45	22.5	10.5

HEATING PART LOAD

Entering Fluid Temp. (°F)	Entering Air Temp. (°F)	Total Capacity (MBtuH)	Leaving Air Temp. (°F)	Power Input (KW)	Heat of Absorption (MBtuH)	COP
25°	65°	11.1	77.8	1.12	7.2	2.9
30°		12.7	79.7	1.12	8.7	3.3
40°		15.9	83.4	1.13	11.9	4.1
50°		19.0	87.0	1.14	15.0	4.9
60°		21.4	89.8	1.14	17.4	5.5
70°		23.8	92.6	1.15	19.9	6.1
80°		26.2	95.4	1.15	22.3	6.7
25°	70°	10.9	82.6	1.15	6.9	2.8
30°		12.4	84.4	1.15	8.5	3.2
40°		15.5	87.9	1.16	11.5	3.9
50°		18.6	91.5	1.17	14.6	4.7
60°		21.0	94.2	1.18	16.9	5.2
70°		23.3	97.0	1.18	19.3	5.79
80°		25.7	99.7	1.19	21.6	6.35
25°	75°	11.0	87.7	1.29	6.7	2.5
30°		12.5	89.5	1.29	8.2	2.8
40°		15.7	93.1	1.30	11.2	3.5
50°		18.8	96.8	1.31	14.2	4.2
60°		21.2	99.5	1.32	16.4	4.7
70°		23.6	102.3	1.33	18.7	5.2
80°		25.9	105.0	1.33	21.0	5.7

QW3S1

Full Load Capacities based upon rated flow of 8 GPM of 15% methanol/mass at 1150 CFM airflow.

COOLING FULL LOAD

Entering Fluid Temp. (°F)	Entering Air Temp. (°F)	Total Capacity (MBtuH)	Sensible Capacity (MBtuH)	Sensible to Total Ratio	Power Input (KW)	Heat of Rejection (MBtuH)	EER
50°	70° DB 59° WB	32.5	22.0	0.67	1.42	36.9	19.3
60°		31.9	22.1	0.69	1.70	37.0	17.5
70°		31.2	22.2	0.71	1.98	37.2	15.8
80°		30.5	22.3	0.73	2.26	37.3	14.0
90°		29.8	22.4	0.75	2.53	37.4	12.2
100°		29.1	22.6	0.77	2.81	37.5	10.4
110°		28.4	22.7	0.80	3.09	37.7	8.6
50°	75° DB 63° WB	34.9	22.8	0.65	1.45	39.6	20.5
60°		34.2	23.0	0.67	1.73	39.8	18.6
70°		33.5	23.1	0.69	2.00	40.0	16.7
80°		32.8	23.3	0.71	2.28	40.1	14.9
90°		32.1	23.4	0.73	2.56	40.3	13.0
100°		31.4	23.6	0.75	2.83	40.5	11.1
110°		30.7	23.8	0.77	3.11	40.6	9.2
50°	80° DB 67° WB	37.5	23.6	0.63	1.48	42.5	21.7
60°		36.7	23.8	0.65	1.75	42.7	19.7
70°		36.0	24.0	0.67	2.03	42.9	17.7
80°		35.3	24.2	0.69	2.31	43.1	15.8
90°		34.5	24.4	0.71	2.58	43.4	13.8
100°		33.8	24.6	0.73	2.86	43.6	11.8
110°		33.1	24.8	0.75	3.14	43.8	9.8
50°	85° DB 71° WB	40.1	24.4	0.60	1.51	45.5	22.8
60°		39.3	24.6	0.62	1.78	45.8	20.8
70°		38.6	24.8	0.64	2.06	46.0	18.7
80°		37.8	25.1	0.66	2.34	46.3	16.7
90°		37.1	25.3	0.68	2.61	46.5	14.6
100°		36.3	25.6	0.70	2.89	46.8	12.6
110°		35.5	25.8	0.72	3.17	47.0	10.5

HEATING FULL LOAD

Entering Fluid Temp. (°F)	Entering Air Temp. (°F)	Total Capacity (MBtuH)	Leaving Air Temp. (°F)	Power Input (KW)	Heat of Absorption (MBtuH)	COP
25°	65°	26.1	86.0	2.19	18.4	3.5
30°		28.2	87.7	2.27	20.2	3.6
40°		32.5	91.2	2.43	24.0	3.9
50°		36.8	94.7	2.58	27.8	4.2
60°		40.5	97.6	2.68	31.1	4.4
70°		44.2	100.6	2.78	34.5	4.7
80°		47.9	103.5	2.87	37.8	4.9
25°		70°	25.5	90.5	2.25	17.8
30°	27.6		92.2	2.33	19.6	3.5
40°	31.8		95.6	2.49	23.3	3.7
50°	36.0		99.0	2.65	27.0	4.0
60°	39.6		101.9	2.75	30.2	4.2
70°	43.2		104.8	2.85	33.5	4.4
80°	46.8		107.7	2.95	36.7	4.7
25°	75°		25.8	95.8	2.53	17.3
30°		27.9	97.5	2.62	19.1	3.1
40°		32.1	100.9	2.80	22.6	3.4
50°		36.4	104.3	2.98	26.1	3.6
60°		40.0	107.2	3.09	29.3	3.8
70°		43.7	110.2	3.20	32.5	4.0
80°		47.3	113.1	3.31	35.6	4.2

Full Load Capacities based upon rated flow of 8 GPM of 15% methanol/mass at 900 CFM airflow.

COOLING PART LOAD

Entering Fluid Temp. (°F)	Entering Air Temp. (°F)	Total Capacity (MBtuH)	Sensible Capacity (MBtuH)	Sensible to Total Ratio	Power Input (KW)	Heat of Rejection (MBtuH)	EER
50°	70° DB 59° WB	26.5	18.4	0.68	0.72	28.7	27.0
60°		24.9	17.8	0.71	0.93	27.8	23.7
70°		23.4	17.2	0.74	1.15	26.9	20.4
80°		21.8	16.6	0.77	1.36	25.9	17.1
90°		20.3	16.0	0.79	1.57	25.0	13.8
100°		18.7	15.4	0.82	1.79	24.1	10.5
110°		17.1	14.8	0.85	2.00	23.1	7.1
50°	75° DB 63° WB	28.5	19.1	0.66	0.73	30.8	28.7
60°		26.8	18.5	0.68	0.94	29.9	25.2
70°		25.1	17.9	0.71	1.16	28.9	21.7
80°		23.5	17.3	0.74	1.37	27.9	18.2
90°		21.8	16.7	0.77	1.59	26.9	14.7
100°		20.2	16.1	0.80	1.80	25.9	11.2
110°		18.5	15.5	0.83	2.02	25.0	7.7
50°	80° DB 67° WB	30.5	19.8	0.63	0.75	33.1	30.3
60°		28.8	19.2	0.66	0.96	32.0	26.7
70°		27.0	18.6	0.69	1.18	31.0	23.0
80°		25.2	18.0	0.72	1.39	30.0	19.3
90°		23.5	17.4	0.75	1.61	28.9	15.6
100°		21.7	16.8	0.77	1.82	27.9	11.9
110°		19.9	16.2	0.80	2.04	26.9	8.2
50°	85° DB 71° WB	32.7	20.4	0.61	0.76	35.4	32.0
60°		30.8	19.8	0.64	0.98	34.3	28.1
70°		28.9	19.3	0.67	1.19	33.2	24.3
80°		27.1	18.7	0.69	1.41	32.1	20.4
90°		25.2	18.1	0.72	1.62	31.1	16.5
100°		23.3	17.5	0.75	1.84	30.0	12.7
110°		21.4	16.9	0.78	2.05	28.9	8.8

HEATING PART LOAD

Entering Fluid Temp. (°F)	Entering Air Temp. (°F)	Total Capacity (MBtuH)	Leaving Air Temp. (°F)	Power Input (KW)	Heat of Absorption (MBtuH)	COP
25°	65°	17.4	82.9	1.55	12.0	3.3
30°		19.0	84.6	1.57	13.5	3.6
40°		22.2	87.8	1.61	16.6	4.0
50°		25.4	91.1	1.65	19.6	4.5
60°		28.8	94.6	1.70	22.9	5.0
70°		32.2	98.2	1.75	26.1	5.4
80°		35.7	101.7	1.81	29.4	5.8
25°		70°	17.1	87.5	1.59	11.6
30°	18.6		89.1	1.61	13.1	3.4
40°	21.7		92.3	1.65	16.1	3.8
50°	24.8		95.5	1.69	19.0	4.3
60°	28.2		99.0	1.75	22.2	4.7
70°	31.5		102.4	1.80	25.4	5.1
80°	34.9		105.9	1.86	28.5	5.5
25°	75°		17.2	92.7	1.79	11.3
30°		18.8	94.3	1.81	12.7	3.0
40°		21.9	97.6	1.85	15.6	3.5
50°		25.1	100.8	1.90	18.5	3.9
60°		28.5	104.3	1.96	21.5	4.2
70°		31.8	107.8	2.02	24.6	4.6
80°		35.2	111.2	2.08	27.7	5.0

QW4S1

Full Load Capacities based upon rated flow of 9 GPM of 15% methanol/mass at 1350 CFM airflow.

COOLING FULL LOAD

Entering Fluid Temp. (°F)	Entering Air Temp. (°F)	Total Capacity (MBtuH)	Sensible Capacity (MBtuH)	Sensible to Total Ratio	Power Input (KW)	Heat of Rejection (MBtuH)	EER
50°	70° DB 59° WB	52.1	32.2	0.59	2.09	58.5	21.4
60°		48.8	31.4	0.63	2.40	56.1	19.1
70°		45.5	30.5	0.67	2.71	53.7	16.8
80°		42.1	29.7	0.71	3.02	51.2	14.4
90°		38.8	28.9	0.75	3.33	48.8	12.1
100°		35.5	28.1	0.79	3.63	46.4	9.8
110°		32.2	27.2	0.83	3.94	43.9	7.4
50°	75° DB 63° WB	56.0	33.4	0.57	2.13	62.9	22.7
60°		52.4	32.6	0.61	2.44	60.3	20.3
70°		48.9	31.8	0.65	2.74	57.7	17.8
80°		45.4	31.0	0.69	3.05	55.2	15.4
90°		41.8	30.2	0.73	3.36	52.6	12.9
100°		38.3	29.4	0.77	3.67	50.0	10.4
110°		34.7	28.5	0.81	3.97	47.5	8.0
50°	80° DB 67° WB	60.0	34.6	0.55	2.17	67.4	24.1
60°		56.3	33.8	0.59	2.47	64.7	21.5
70°		52.5	33.0	0.63	2.78	62.0	18.9
80°		48.7	32.2	0.67	3.09	59.3	16.3
90°		45.0	31.4	0.70	3.39	56.5	13.7
100°		41.2	30.6	0.74	3.7	53.8	11.1
110°		37.4	29.8	0.78	4.01	51.1	8.6
50°	85° DB 71° WB	64.3	35.7	0.53	2.21	72.2	25.3
60°		60.3	34.9	0.57	2.51	69.3	22.6
70°		56.3	34.2	0.61	2.82	66.4	19.9
80°		52.3	33.4	0.64	3.13	63.6	17.2
90°		48.3	32.6	0.68	3.43	60.7	14.5
100°		44.2	31.8	0.72	3.74	57.8	11.8
110°		40.2	31.0	0.76	4.04	54.9	9.1

HEATING FULL LOAD

Entering Fluid Temp. (°F)	Entering Air Temp. (°F)	Total Capacity (MBtuH)	Leaving Air Temp. (°F)	Power Input (KW)	Heat of Absorption (MBtuH)	COP
25°	65°	33.0	87.6	2.89	22.8	3.4
30°		35.3	89.2	2.97	24.8	3.5
40°		39.9	92.4	3.12	29.0	3.7
50°		44.6	95.6	3.26	33.1	4.0
60°		50.0	99.3	3.47	37.8	4.2
70°		55.4	103.0	3.67	42.6	4.4
80°		60.9	106.7	3.88	47.3	4.6
25°	70°	32.2	92.1	2.97	22.1	3.2
30°		34.5	93.7	3.05	24.1	3.3
40°		39.1	96.8	3.20	28.1	3.6
50°		43.6	99.9	3.35	32.2	3.8
60°		48.9	103.5	3.56	36.7	4.0
70°		54.2	107.2	3.77	41.3	4.2
80°		59.5	110.8	3.98	45.9	4.4
25°	75°	32.6	97.3	3.33	21.4	2.9
30°		34.9	98.9	3.42	23.4	3.0
40°		39.5	102.1	3.59	27.3	3.2
50°		44.1	105.2	3.76	31.2	3.4
60°		49.4	108.9	4.00	35.6	3.6
70°		54.8	112.6	4.23	40.1	3.8
80°		60.2	116.3	4.47	44.5	4.0

Full Load Capacities based upon rated flow of 9 GPM of 15% methanol/mass at 1150 CFM airflow.

COOLING PART LOAD

Entering Fluid Temp. (°F)	Entering Air Temp. (°F)	Total Capacity (MBtuH)	Sensible Capacity (MBtuH)	Sensible to Total Ratio	Power Input (KW)	Heat of Rejection (MBtuH)	EER
50°	70° DB 59° WB	37.4	26.7	0.71	1.07	40.8	26.6
60°		35.4	25.5	0.72	1.36	39.6	23.5
70°		33.4	24.4	0.73	1.64	38.4	20.3
80°		31.4	23.3	0.74	1.93	37.2	17.2
90°		29.4	22.2	0.76	2.21	36.0	14.1
100°		27.4	21.1	0.77	2.50	34.9	11.0
110°		25.4	20.0	0.78	2.78	33.7	7.9
50°	75° DB 63° WB	40.2	27.7	0.68	1.09	43.8	28.2
60°		38.1	26.6	0.69	1.38	42.5	24.9
70°		36.0	25.4	0.71	1.66	41.3	21.6
80°		33.8	24.3	0.72	1.95	40.1	18.3
90°		31.7	23.2	0.73	2.23	38.8	15.0
100°		29.6	22.1	0.75	2.52	37.6	11.7
110°		27.4	20.9	0.76	2.80	36.4	8.5
50°	80° DB 67° WB	43.1	28.7	0.66	1.12	46.9	29.8
60°		40.9	27.5	0.67	1.40	45.6	26.4
70°		38.6	26.4	0.68	1.69	44.4	22.9
80°		36.3	25.3	0.70	1.97	43.1	19.4
90°		34.1	24.1	0.71	2.26	41.8	16.0
100°		31.8	23.0	0.72	2.54	40.5	12.5
110°		29.5	21.9	0.74	2.83	39.2	9.1
50°	85° DB 71° WB	46.2	29.6	0.63	1.14	50.3	31.4
60°		43.8	28.5	0.65	1.42	48.9	27.8
70°		41.4	27.3	0.66	1.71	47.5	24.2
80°		39.0	26.2	0.67	1.99	46.2	20.6
90°		36.6	25.0	0.69	2.28	44.8	16.9
100°		34.1	23.9	0.70	2.57	43.5	13.3
110°		31.7	22.8	0.71	2.85	42.1	9.7

HEATING PART LOAD

Entering Fluid Temp. (°F)	Entering Air Temp. (°F)	Total Capacity (MBtuH)	Leaving Air Temp. (°F)	Power Input (KW)	Heat of Absorption (MBtuH)	COP
25°	65°	23.1	83.6	2.09	15.7	3.2
30°		25.1	85.2	2.12	17.6	3.5
40°		29.0	88.4	2.17	21.4	3.9
50°		32.9	91.5	2.22	25.2	4.3
60°		36.4	94.3	2.26	28.5	4.7
70°		39.9	97.1	2.30	31.9	5.1
80°		43.4	99.9	2.34	35.2	5.5
25°	70°	22.6	88.2	2.15	15.2	3.1
30°		24.5	89.7	2.18	17.1	3.3
40°		28.4	92.8	2.23	20.7	3.7
50°		32.2	95.9	2.28	24.4	4.1
60°		35.6	98.7	2.32	27.7	4.5
70°		39.0	101.4	2.36	30.9	4.8
80°		42.4	104.1	2.40	34.2	5.2
25°	75°	22.8	93.4	2.42	14.8	2.8
30°		24.8	94.9	2.44	16.6	3.0
40°		28.7	98.1	2.50	20.1	3.3
50°		32.6	101.2	2.56	23.7	3.7
60°		36.0	104.0	2.60	26.9	4.0
70°		39.4	106.7	2.65	30.0	4.4
80°		42.9	109.5	2.70	33.2	4.7

QW5S1

Full Load Capacities based upon rated flow of 11 GPM of 15% methanol/mass at 1450 CFM airflow.

COOLING FULL LOAD

Entering Fluid Temp. (°F)	Entering Air Temp. (°F)	Total Capacity (MBtuH)	Sensible Capacity (MBtuH)	Sensible to Total Ratio	Power Input (KW)	Heat of Rejection (MBtuH)	EER
50°	70° DB 59° WB	55.3	36.1	0.65	2.37	62.6	19.6
60°		53.2	35.3	0.66	2.82	61.8	17.6
70°		51.1	34.5	0.68	3.26	61.0	15.7
80°		49.0	33.7	0.69	3.71	60.2	13.7
90°		46.9	32.9	0.70	4.15	59.4	11.74
100°		44.8	32.1	0.72	4.60	58.6	9.7
110°		42.7	31.3	0.73	5.04	57.8	7.8
50°	75° DB 63° WB	59.4	37.5	0.63	2.41	67.2	20.8
60°		57.2	36.7	0.64	2.86	66.4	18.7
70°		55.0	35.9	0.65	3.30	65.6	16.6
80°		52.7	35.2	0.67	3.75	64.8	14.6
90°		50.5	34.4	0.68	4.19	64.0	12.5
100°		48.3	33.6	0.69	4.64	63.2	10.4
110°		46.1	32.8	0.71	5.08	62.4	8.4
50°	80° DB 67° WB	63.7	38.8	0.60	2.46	72.1	22.0
60°		61.3	38.1	0.62	2.90	71.2	19.1
70°		59.0	37.3	0.63	3.35	70.4	17.6
80°		56.7	36.5	0.65	3.79	69.6	15.5
90°		54.3	35.8	0.66	4.24	68.8	13.3
100°		52.0	35.0	0.67	4.68	68.0	11.1
110°		49.7	34.2	0.69	5.12	67.2	8.9
50°	85° DB 71° WB	68.2	40.1	0.58	2.51	77.1	23.1
60°		65.7	39.4	0.60	2.95	76.3	20.9
70°		63.2	38.6	0.61	3.40	75.5	18.6
80°		60.8	37.9	0.62	3.84	74.7	16.3
90°		58.3	37.1	0.64	4.28	73.8	14.1
100°		55.8	36.4	0.65	4.73	73.0	11.8
110°		53.4	35.6	0.66	5.17	72.2	9.5

HEATING FULL LOAD

Entering Fluid Temp. (°F)	Entering Air Temp. (°F)	Total Capacity (MBtuH)	Leaving Air Temp. (°F)	Power Input (KW)	Heat of Absorption (MBtuH)	COP
25°	65°	42.2	91.9	3.83	28.7	3.2
30°		45.0	93.7	3.94	31.1	3.3
40°		50.6	97.3	4.18	35.9	3.5
50°		56.3	100.9	4.42	40.7	3.7
60°		62.7	105.0	4.71	46.1	3.9
70°		69.1	109.1	5.00	51.5	4.0
80°		75.4	113.2	5.28	56.9	4.2
25°	70°	41.3	96.3	3.93	27.8	3.1
30°		44.0	98.1	4.05	30.2	3.2
40°		49.5	101.6	4.3	34.8	3.4
50°		55.0	105.1	4.54	39.5	3.5
60°		61.3	109.1	4.84	44.7	3.7
70°		67.5	113.1	5.13	50.0	3.9
80°		73.8	117.1	5.43	55.2	4.0
25°	75°	41.7	101.6	4.41	27.0	2.8
30°		44.5	103.4	4.55	29.3	2.9
40°		50.0	107.0	4.82	33.8	3.0
50°		55.6	110.5	5.10	38.3	3.2
60°		61.9	114.5	5.43	43.4	3.3
70°		68.2	118.6	5.76	48.5	3.5
80°		74.6	122.6	6.09	53.6	3.6

Full Load Capacities based upon rated flow of 11 GPM of 15% methanol/mass at 1250 CFM airflow.

COOLING PART LOAD

Entering Fluid Temp. (°F)	Entering Air Temp. (°F)	Total Capacity (MBtuH)	Sensible Capacity (MBtuH)	Sensible to Total Ratio	Power Input (KW)	Heat of Rejection (MBtuH)	EER
50°	70° DB 59° WB	43.4	29.4	0.67	1.41	47.8	23.7
60°		41.4	28.6	0.69	1.78	46.9	21.0
70°		39.5	27.8	0.70	2.16	46.0	18.3
80°		37.5	26.9	0.72	2.53	45.2	15.6
90°		35.6	26.1	0.74	2.91	44.3	12.9
100°		33.6	25.3	0.75	3.29	43.4	10.2
110°		31.6	24.5	0.77	3.66	42.6	7.5
50°	75° DB 63° WB	46.6	30.5	0.65	1.43	51.3	25.1
60°		44.5	29.7	0.66	1.81	50.4	22.3
70°		42.5	28.9	0.68	2.19	49.5	19.4
80°		40.4	28.1	0.70	2.56	48.6	16.6
90°		38.3	27.3	0.71	2.94	47.7	13.8
100°		36.2	26.5	0.73	3.31	46.9	10.9
110°		34.2	25.7	0.75	3.69	46.0	8.1
50°	80° DB 67° WB	50.0	31.6	0.62	1.46	55.0	26.5
60°		47.8	30.8	0.64	1.84	54.1	23.6
70°		45.6	30.0	0.66	2.22	53.2	20.6
80°		43.4	29.2	0.67	2.59	52.2	17.6
90°		41.2	28.4	0.69	2.97	51.3	14.6
100°		39.0	27.6	0.71	3.35	50.4	11.7
110°		36.8	26.8	0.72	3.72	49.5	8.7
50°	85° DB 71° WB	53.5	32.6	0.60	1.49	58.9	28.0
60°		51.2	31.8	0.62	1.87	57.9	24.9
70°		48.9	31.1	0.64	2.25	57.0	21.7
80°		46.5	30.3	0.65	2.62	56.0	18.6
90°		44.2	29.5	0.67	3.00	55.1	15.5
100°		41.9	28.7	0.68	3.38	54.1	12.4
110°		39.5	27.9	0.70	3.76	53.2	9.3

HEATING PART LOAD

Entering Fluid Temp. (°F)	Entering Air Temp. (°F)	Total Capacity (MBtuH)	Leaving Air Temp. (°F)	Power Input (KW)	Heat of Absorption (MBtuH)	COP
25°	65°	30.8	87.8	2.85	20.7	3.2
30°		32.9	89.4	2.90	22.7	3.3
40°		37.2	92.6	3.00	26.6	3.6
50°		41.5	95.8	3.11	30.6	3.9
60°		46.4	99.4	3.21	35.2	4.2
70°		51.4	103.0	3.32	39.7	4.5
80°		56.3	106.7	3.43	44.3	4.8
25°	70°	30.1	92.3	2.93	20.1	3.0
30°		32.2	93.9	2.98	22.0	3.2
40°		36.4	97.0	3.09	25.9	3.4
50°		40.6	100.1	3.19	29.7	3.7
60°		45.4	103.6	3.30	34.1	4.0
70°		50.2	107.2	3.41	38.6	4.3
80°		55.0	110.7	3.52	43.0	4.6
25°	75°	30.4	97.5	3.29	19.5	2.7
30°		32.6	99.1	3.35	21.4	2.9
40°		36.8	102.3	3.46	25.1	3.1
50°		41.0	105.4	3.58	28.8	3.4
60°		45.9	109.0	3.71	33.1	3.6
70°		50.8	112.6	3.83	37.4	3.9
80°		55.6	116.2	3.95	41.7	4.1

Water Coil Pressure Drop (Fresh Water)

Model	QW2S & QW3S		QW4S		QW5S	
	PSID	Ft. Hd.	PSID	Ft. Hd.	PSID	Ft. Hd.
3	0.1	0.23				
4	0.5	1.15	0.9	2.08		
5	1.2	2.77	1.4	3.23		
6	1.7	3.92	2.3	5.31		
7	2.3	5.31	3.2	7.38	2	4.61
8	3.1	7.15	4.1	9.46	2.5	5.77
9	4.1	9.46	5.1	11.77	3.2	7.38
10			6.1	14.07	3.9	9.00
11			7.1	16.38	4.7	10.84
12			8.2	18.92	5.5	12.69
13			9.4	21.69	6.4	14.76
14			10.6	24.45	7.3	16.84
15					8.1	18.69
16					9	20.76
17					9.9	22.84
18						

NOTE:

For pump options 3, 4 and 5 add 1.5 head to Table values as allowance for QW*S internal piping.

Additional feet head allowance for external piping to loop must be included and determined by others.

Required Flow Rates for Water Loop Installations

	QW2S	QW3S	QW4S	QW5S
Flow rate required GPM fresh water	6.1	8.6	11.3	13.7

Required Flow Rates for Ground Loop Installations

	QW2S	QW3S	QW4S	QW5S
Flow rate required GPM Methanol, Propylene Glycol or Ethanol ①	7	8	9	11

① See Antifreeze table below.

Antifreeze Percentages by Volume for Ground Loop Installations ①

Type	Minimum Temperature for Freeze Protection			
	10°F (-12.2°C)	15°F (-9.4°C)	20°F (-6.7°C)	25°F (-3.9°C)
Methanol	25%	21%	16%	10%
Ethanol ②	29%	25%	20%	14%
100% USP Food Grade Propylene Glycol	27%	24%	20%	13%

① Loop antifreeze protection must be determined based on loop design and geographic location.

② Must not be denatured with any petroleum based product.

Ventilation System Packages — Optional

Q-Tec models are designed to provide optional ventilation packages to meet all of your ventilation and indoor air quality requirements. All ventilation packages are factory installed. If no option is ordered, the ventilation intake and exhaust are sealed with a blank-off plate.

NOTE: A ventilation wall sleeve QWVS42 with outdoor louver grille is required for all installations that intend to utilize one of the built-in ventilation options of the QW*S Series heat pumps. If a ventilation option is not to be utilized, do not order ventilation wall sleeve.

COMMERCIAL ROOM VENTILATOR (Option V)

OPTIONAL

The built-in commercial room ventilator is internally mounted and allows outside ventilation air, up to 50% of the total airflow rating of the unit, to be introduced through the ventilation louver grille. It includes a built-in exhaust air damper. Spring return on power loss or deactivation. The commercial room ventilator (CRV) is a simple and innovative approach to improving the indoor air quality by providing fresh air intake and exhaust capability through the CRV. The damper can be easily adjusted to control the amount of fresh air supplied into the building. The CRV can be controlled by indoor blower operation or field controlled based on room occupancy. Complies with ANSI/ASHRAE Standard 62.1 "Ventilation for Acceptable Indoor Air Quality".

ENERGY RECOVERY VENTILATOR (Option R)

OPTIONAL

The energy recovery ventilator (ERV) is a highly innovative approach to meeting indoor air quality ventilation requirements as established by ANSI/ASHRAE Standard 62.1. The ERV is internally mounted and allows up to 450 CFM (depending upon speed setting) of fresh air and exhaust through the unit while maintaining superior indoor comfort and humidity levels. In most cases this can be accomplished without increasing equipment sizing or operating costs. Heat transfer efficiency is up to 64% during summer and 79% during winter conditions.

The ERV consists of a unique "rotary energy recovery cassette" that provides effective sensible and latent heat transfer capabilities during summer and winter conditions. Various control schemes are addressed including limiting ventilation during building occupancy only. The ERV has a filter for the exhaust air to keep the rotary wheels clean and free of any debris introduced through the room return air grille. The intake and exhaust rates can be independently selected. Factory set on medium intake and low exhaust. Intake and exhaust air paths have shut-off dampers to eliminate the ingress of outside air when ventilation system is off.

ELECTRICAL SPECIFICATIONS

MODEL	RATED VOLTS & PHASE	NO. FIELD POWER CIRCUITS	③ MINIMUM CIRCUIT AMPACITY	① MAXIMUM EXTERNAL FUSE OR CIRCUIT BREAKER	② FIELD POWER WIRE SIZE	② GROUND WIRE SIZE
QW2S1-A0Z	230/208-1	1	18	30	10	10
QW2S1-B0Z	230/208-3	1	13	20	12	12
QW2S1-C0Z	460-3	1	7	10	14	14
QW3S1-A0Z	230/208-1	1	26	40	8	10
QW3S1-B0Z	230/208-3	1	19	30	10	10
QW3S1-C0Z	460-3	1	8	15	14	14
QW4S1-A0Z	230/208-1	1	31	50	8	10
QW4S1-B0Z	230/208-3	1	27	40	8	10
QW4S1-C0Z	460-3	1	11	20	12	12
QW5S1-A0Z	230/208-1	1	38	60	8	10
QW5S1-B0Z	230/208-3	1	28	45	8	10
QW5S1-C0Z	460-3	1	16	25	10	10

① Maximum size of the time delay fuse or HACR type circuit breaker for protection of field wiring conductors.

② Based on 75°C copper wire. All wiring must conform to the National Electrical Code and all local codes.

③ These "Minimum Circuit Ampacity" values are to be used for sizing the field power conductors. Refer to the National Electrical Code (latest revision) article 310 for power conductor sizing.

QW2S CRV AIRFLOW VS. DAMPER POSITION

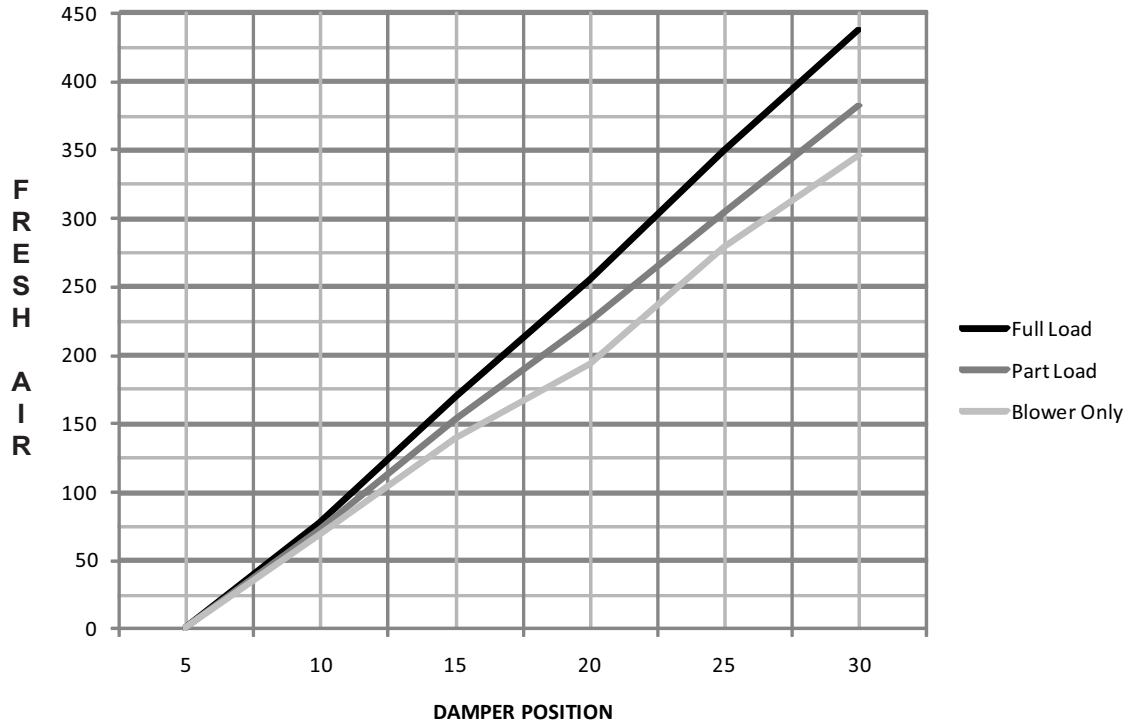

QW3S CRV AIRFLOW VS. DAMPER POSITION

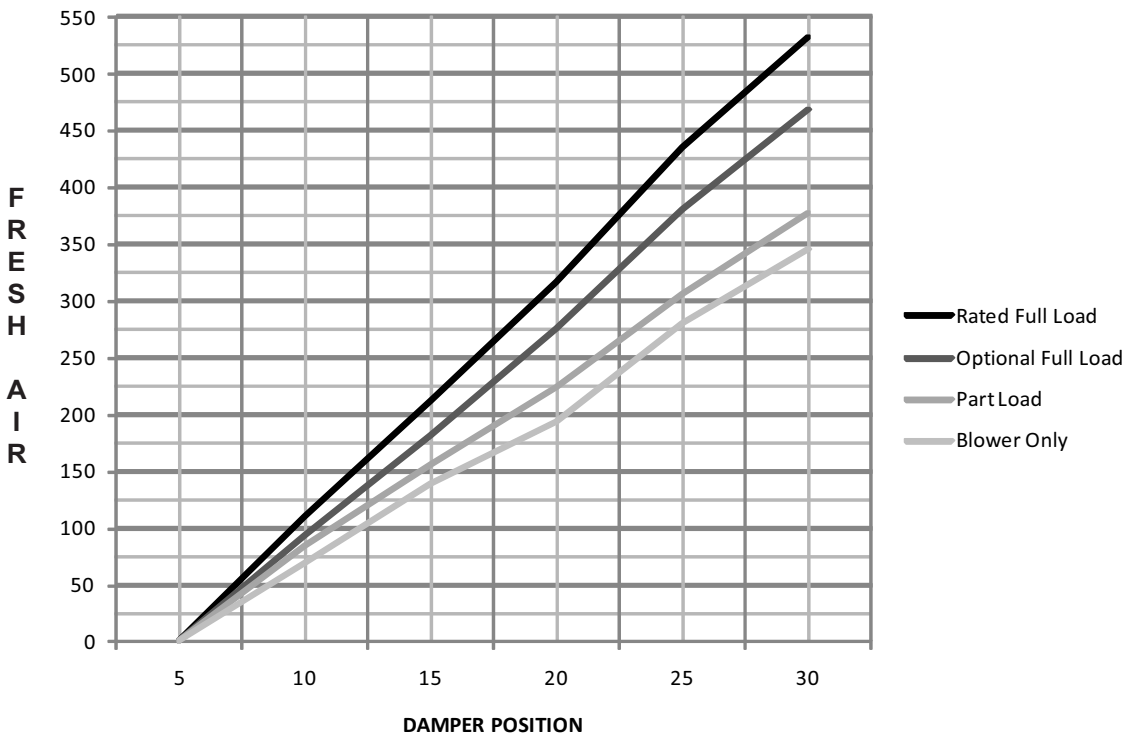

QW4S CRV AIRFLOW VS. DAMPER POSITION

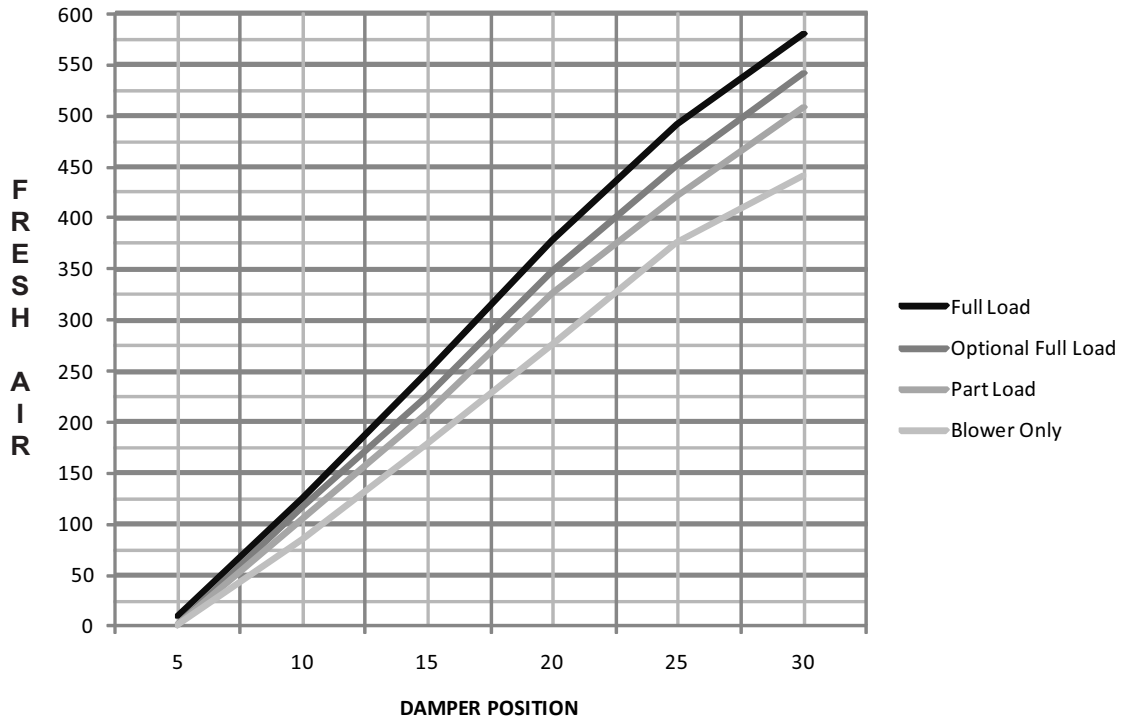

QW5S CRV AIRFLOW VS. DAMPER POSITION

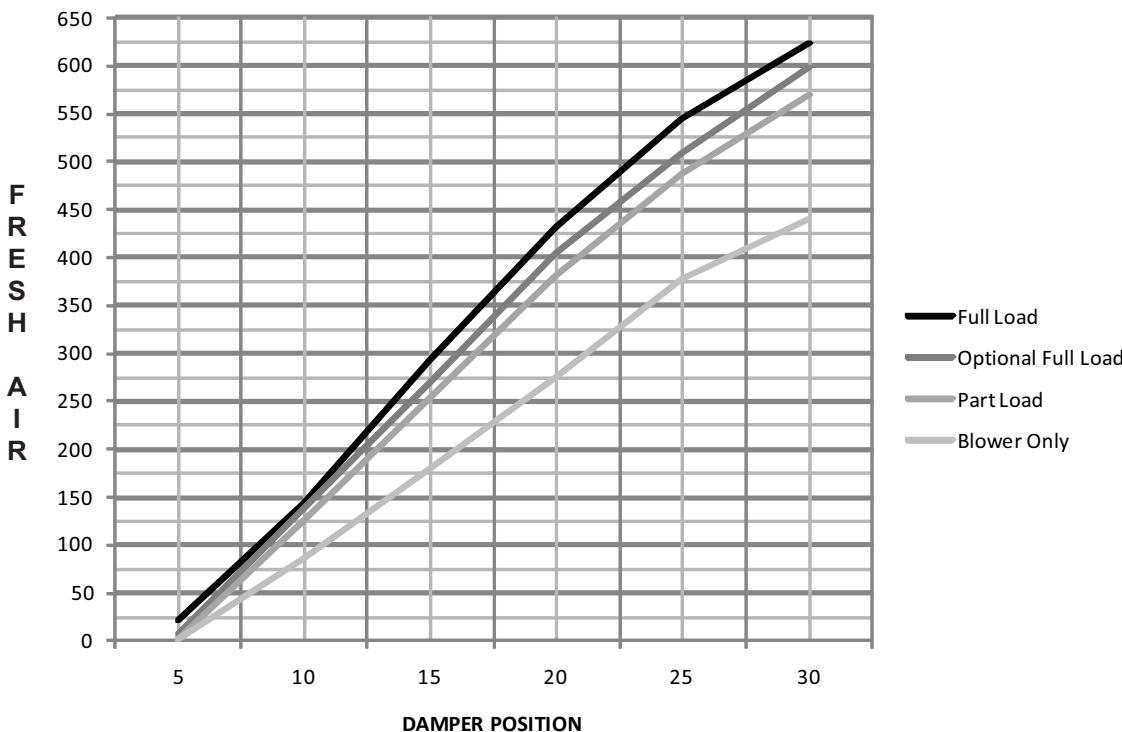

Energy Recovery Ventilator Performance Tables

Ambient O.D.	VENTILATION RATE – 450 CFM 65% Efficiency						VENTILATION RATE – 375 CFM 66% Efficiency						VENTILATION RATE – 300 CFM 67% Efficiency						
	DB/WB DegreesF	VLT	VLS	VLL	HRT	HRS	HRL	VLT	VLS	VLL	HRT	HRS	HRL	VLT	VLS	VLL	HRT	HRS	HRL
75	21465	14580	6884	13952	9477	4475	17887	12150	5737	11805	8018	3786	14310	9720	4590	9587	6512	3075	
105	70	14580	14580	0	9477	9477	0	12150	12150	0	8018	8018	0	9720	9720	0	6512	6512	0
65	14580	14580	0	9477	9477	0	12150	12150	0	8018	8018	0	9720	9720	0	6512	6512	0	
80	31590	12150	19440	20533	7897	12635	26325	10125	16200	17374	6682	10692	21060	8100	12960	14110	5427	8683	
75	21465	12150	9314	13952	7897	6054	17887	10125	7762	11805	6682	5123	14310	8100	6210	9587	5427	4160	
100	70	12352	12150	202	8029	7897	131	10293	10125	168	6793	6682	111	8235	8100	135	5517	5427	90
65	12150	12150	0	7897	7897	0	10125	10125	0	6682	6682	0	8100	8100	0	5427	5427	0	
60	12150	12150	0	7897	7897	0	10125	10125	0	6682	6682	0	8100	8100	0	5427	5427	0	
80	31590	9720	21870	20533	6318	14215	26325	8100	18225	17374	5345	12028	21060	6480	14580	14110	4341	9768	
75	21465	9720	11744	13952	6318	7634	17887	8100	9787	11805	5345	6459	14310	6480	7830	9587	4341	5246	
95	70	12352	9720	2632	8029	6318	1711	10293	8100	2193	6793	5345	1447	8235	6480	1755	5517	4341	1175
65	9720	9720	0	6318	6318	0	8100	8100	0	5345	5345	0	6480	6480	0	4341	4341	0	
60	9720	9720	0	6318	6318	0	8100	8100	0	5345	5345	0	6480	6480	0	4341	4341	0	
80	31590	7290	24300	20533	4738	15794	26325	6075	20250	17374	4009	13365	21060	4860	16200	14110	3256	10854	
75	21465	7290	14175	13952	4738	9213	17887	6075	11812	11805	4009	7796	14310	4860	9450	9587	3256	6331	
90	70	12352	7290	5062	8029	4738	3290	10293	6075	4218	6793	4009	2784	8235	4860	3375	5517	3256	2261
65	7290	7290	0	4738	4738	0	6075	6075	0	4009	4009	0	4860	4860	0	3256	3256	0	
60	7290	7290	0	4738	4738	0	6075	6075	0	4009	4009	0	4860	4860	0	3256	3256	0	
80	31590	4860	26730	20533	3159	17374	26325	4050	22275	17374	2672	14701	21060	3240	17820	14110	2170	11939	
75	21465	4860	16605	13952	3159	10793	17887	4050	13837	11805	2672	9132	14310	3240	11070	9857	2170	7416	
85	70	12352	4860	7492	8029	3159	4870	10293	4050	6243	6793	2672	4120	8235	3240	4995	5517	2170	3346
65	4860	4860	0	3159	3159	0	4050	4050	0	2672	2672	0	3240	3240	0	2170	2170	0	
60	4860	4860	0	3159	3159	0	4050	4050	0	2672	2672	0	3240	3240	0	2170	2170	0	
75	21465	2430	19035	13952	1579	12372	17887	2025	15862	11805	1336	10469	14310	1620	12690	9587	1085	8502	
70	12352	2430	9922	8029	1579	6449	10293	2025	8268	6793	1336	5457	8235	1620	6615	5517	1085	4432	
65	4252	2430	1822	2764	1579	1184	3543	2025	1518	2338	1336	1002	2835	1620	1215	1899	1085	814	
60	2430	2430	0	1579	1579	0	2025	2025	0	1336	1336	0	1620	1620	0	1085	1085	0	
70	12352	0	12352	8029	0	8029	10293	0	10293	6793	0	6793	8235	0	8235	5517	0	5517	
75	65	4252	0	4252	2764	0	2764	3543	0	3543	2338	0	2338	2835	0	2835	1899	0	1899
60	0	0	0	0	0	0	0	0	0	0	0	0	0	0	0	0	0	0	

LEGEND

VLT = Ventilation Load – Total
 VLS = Ventilation Load – Sensible
 VLL = Ventilation Load – Latent

HRT = Heat Recovery – Total
 HRS = Heat Recovery – Sensible
 HRL = Heat Recovery – Latent

**WINTER HEATING PERFORMANCE
 (INDOOR DESIGN CONDITIONS 70° F DB)**

Ambient O.D.	VENTILATION RATE						
	DB Degrees F	450 CFM 80% Eff.		375 CFM 81% Eff.		300 CFM 82% Eff.	
		WVL	WHR	WVL	WHR	WVL	WHR
65	2430	1944	2025	1640	1620	1328	
60	4860	3888	4050	3280	3240	2656	
55	7290	5832	6075	4920	4860	3985	
50	9720	7776	8100	6561	6480	5313	
45	12150	9720	10125	8201	8100	6642	
40	14580	11664	12150	9841	9720	7970	
35	17010	13608	14175	11481	11340	9298	
30	19440	15552	16200	13122	12960	10627	
25	21870	17496	18225	14762	14580	11955	
20	24300	19440	20250	16402	16200	13284	
15	26730	21384	22275	18042	17820	14612	

LEGEND

WVL=Winter Ventilation Load
 WHR=Winter Heat Recovery

NOTE: Sensible performance only is shown for winter application.

Optional Hot Water Coil Performance – Heating Capacity @ 180°F Water & 70°F Return Air

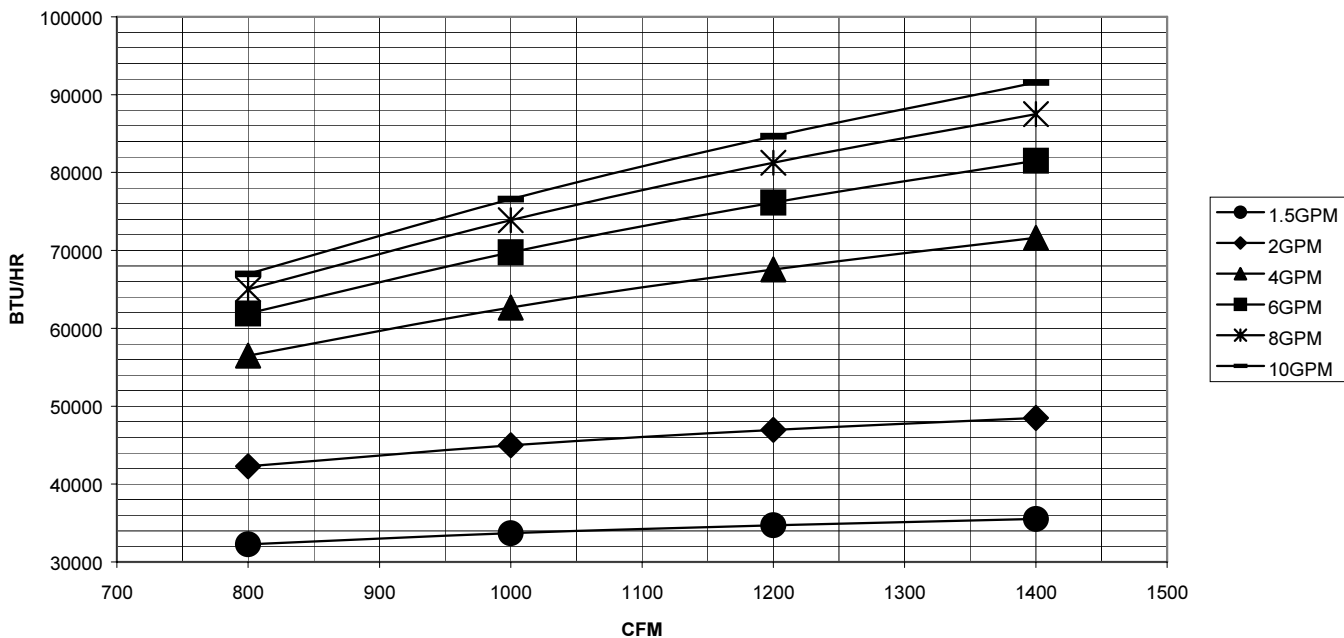

Hot Water Coil Correction Factors

Entering Air Temp (F)	Entering Water Temperature (F)										
	100	110	120	130	140	150	160	170	180	190	200
50	0.455	0.545	0.636	0.727	0.818	0.909	1.000	1.091	1.182	1.273	1.364
55	0.409	0.500	0.591	0.682	0.773	0.864	0.955	1.045	1.136	1.227	1.318
60	0.363	0.455	0.545	0.636	0.727	0.818	0.909	1.000	1.091	1.182	1.273
65	0.318	0.409	0.500	0.591	0.682	0.773	0.864	0.955	1.045	1.136	1.227
70	0.272	0.363	0.455	0.545	0.636	0.727	0.818	0.909	1.000	1.091	1.182
75	0.227	0.318	0.409	0.500	0.591	0.682	0.773	0.864	0.955	1.045	1.136
80	0.182	0.272	0.363	0.455	0.545	0.636	0.727	0.818	0.909	1.000	1.091

Installation Overview of Ventilation Wall Sleeve

Exterior Wall View

NOTE: OPENING DIMENSIONS ARE $\pm .250$

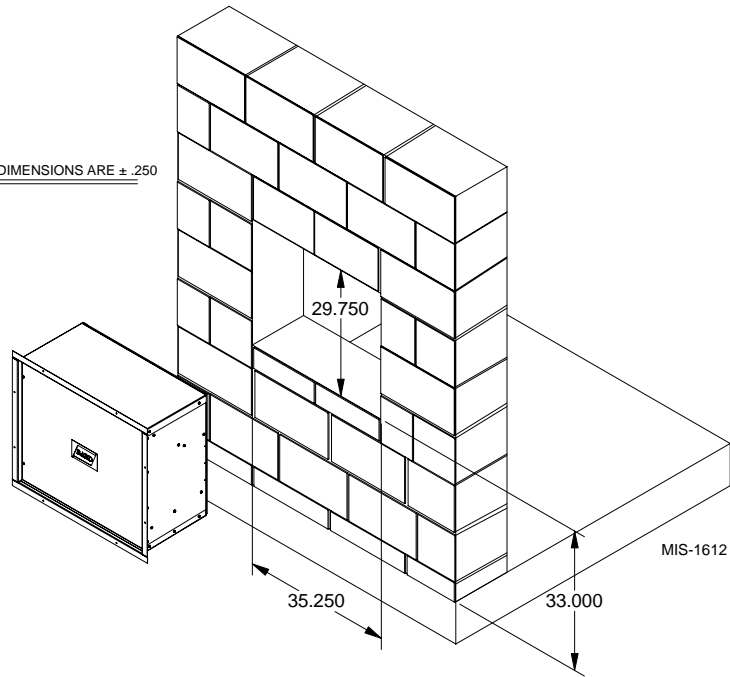

NOTE: Wall opening and wall sleeve required only when one of the ventilation options is utilized. Installations not utilizing any ventilation option can be made in any interior space accessible to electrical supply, water supply system and condensate drain.

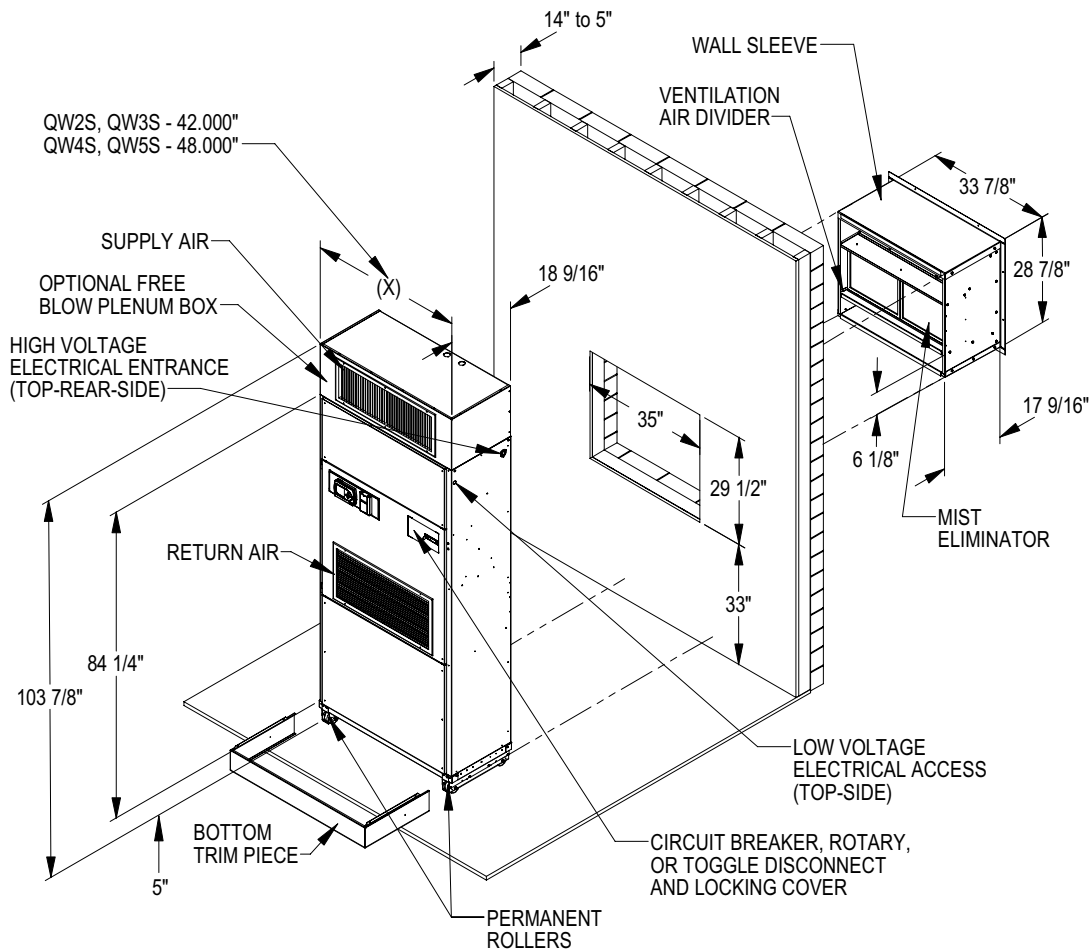

MIS-2739 A

Installation Overview — Unit Installed with Free Blow Plenum Box

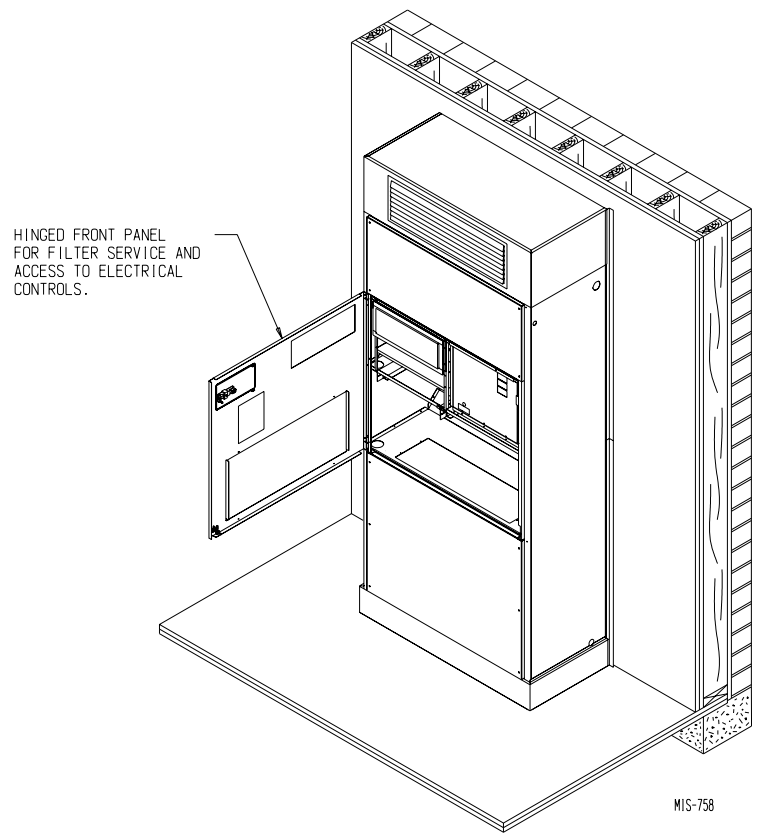

Dimensions of Basic Unit for Architectural and Installation Requirements (Nominal)

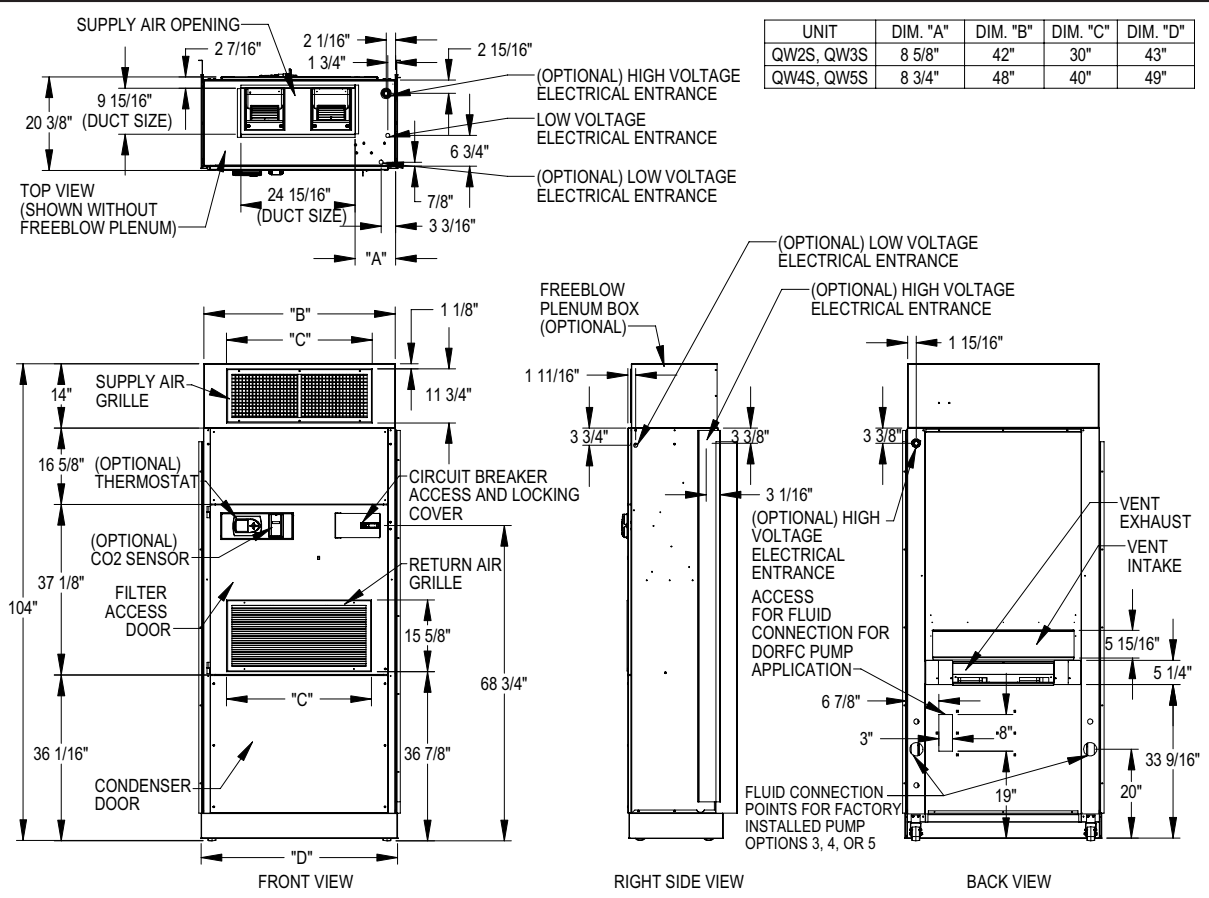

QRS-Series Sound Plenum

The QRS3 - QRS5 Series Sound Plenum has been designed for use with QW*S units. Installation is quick and easy with removal/replacement of six existing screws from the unit cabinet. Once installed the sound plenum enhances the current quiet operation of the Q-Tec Series units, and the hinged door with cam locks (one lockable) provides easy access to the basic Q-Tec system. Model selection is based on equipment cabinet size and finish.

Sound Plenum Part Number	Plenum Finish	Compatible with Equipment Selection
QRS3-X QRS3-4 QRS3-V	Painted Steel - Beige Painted Steel - Buckeye Gray Texture Vinyl ①	QW2S & QW3S
QRS5-X QRS5-4 QRS5-V	Painted Steel - Beige Painted Steel - Buckeye Gray Texture Vinyl ①	QW4S & QW5S

① Front Panels Slate Finish; Side Panels Gray Paint.

UNIT	DIM. "A"
QRS3	42"
QRS5	48"

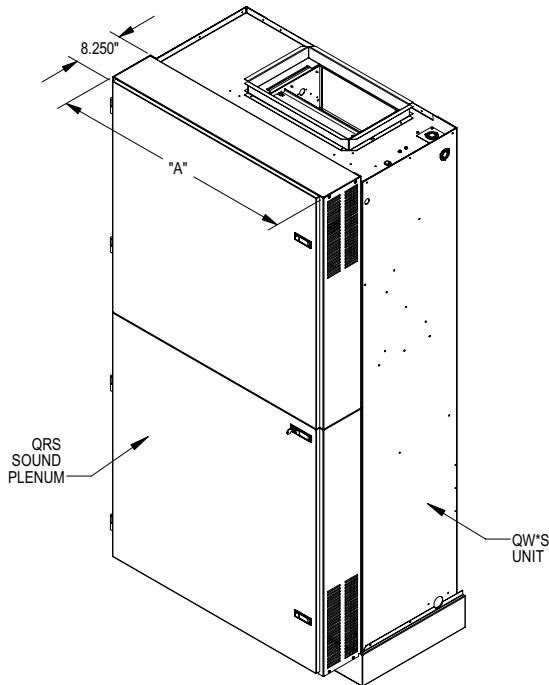

Features:

- Compatible with new or existing QWS units.
- Removable cam latch hinged doors, with center latch lockable.
- Easy unit service design.
- Sound absorbing insulation.
- Reduces equipment operating levels and general muffling of basic unit operation. Actual sound reduction may vary depending upon site variables.

MIS-2794

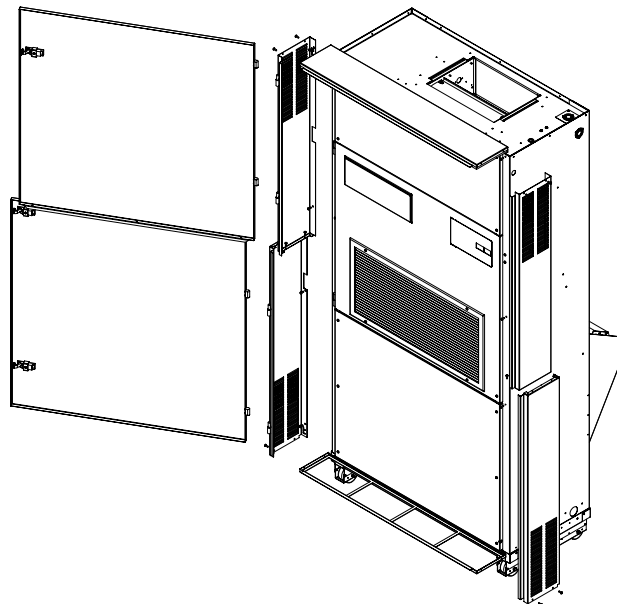

QRASP – Series Return Air Sound Plenum

The QRASP3 - QRASP5 Series Sound Plenum has been designed for use with sound absorbing side panels. It is similar in design to the QSP Sound Plenum, but also incorporates additional sound attenuation panels on both sides as shown. Installation is quick and easy with removal/replacement of six existing screws from the unit cabinet. Once installed the sound plenum enhances the current quiet operation of the Q-Tec Series units, and the hinged door with cam locks (one lockable) provides easy access to the basic Q-Tec system. Model selection is based on equipment cabinet size and finish.

Sound Plenum Part Number	Plenum Finish	Compatible with Equipment Selection
QRASP3-X QRASP3-4 QRASP3-V	Painted Steel - Beige Painted Steel - Buckeye Gray Texture Vinyl ①	QW2S & QW3S
QRASP5-X QRASP5-4 QRASP5-V	Painted Steel - Beige Painted Steel - Buckeye Gray Texture Vinyl ①	QW4S & QW5S

① Front Panels Slate Finish; Side Panels Gray Paint.

Features:

- Compatible with new or existing QWS units.
- Removable cam latch hinged doors, with center latch lockable.
- Easy unit service design.
- Incorporates additional sound absorbing side panels.
- Sound absorbing insulation.
- Reduces equipment operating levels and general muffling of basic unit operation. Actual sound reduction may vary depending upon site variables.

UNIT	DIM A
QRASP3	55 13/16"
QRASP5	61 13/16"

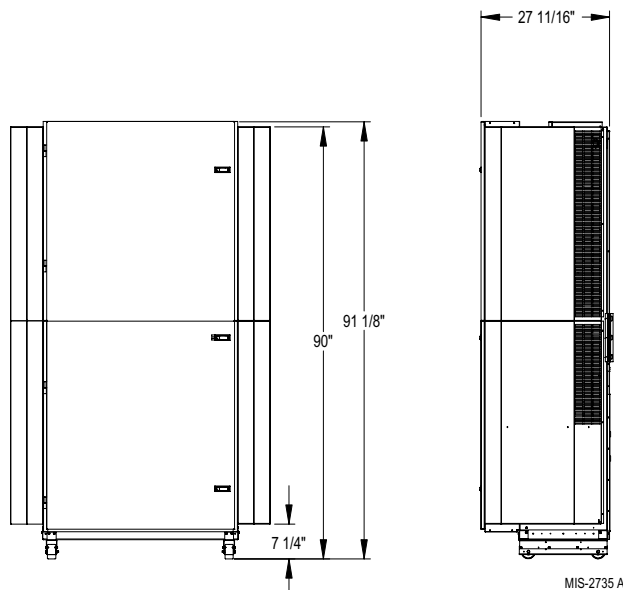
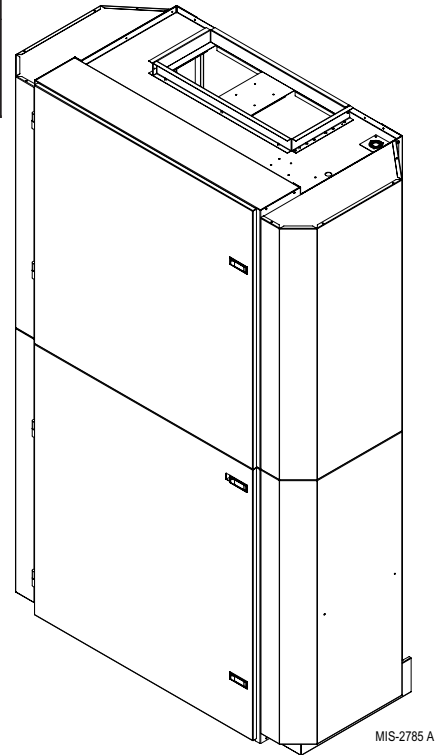
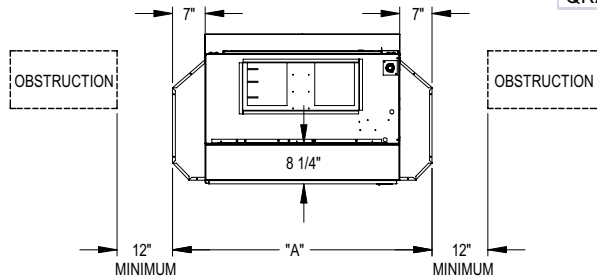

Reserved for Sound Data

Reserved for Sound Data

Optional Accessories – Must be Used for Each Installation with Ventilation Options

Ventilation Wall Sleeves:

QWVS42 Ventilation wall sleeve for walls up to 14 inches thick. **NOTE:** Unless they are to be field-supplied, side trim kit must be ordered for all installations.

Ventilation Louvers:

- QLG-11 Clear Anodized Aluminum for vent option
- QLG-21 Medium Bronze Anodized for vent option
- QLG-31 Dark Bronze Anodized Aluminum for vent option

Side Trim Kits — Required for All Installations Unless Field-Supplied

NOTE: The following accessory items must be selected so the finish (color) is matched to the QWS model that they will be used with.

Side Trim Extension Kits:

Model	Color	Model	Color	Model	Color	Space from back of unit to wall	Unit Compatibility
QSTX-V-6	Platinum Vinyl	QSTX-4-6	Gray Paint	QSTX-X-6	Beige Paint	4" to 6"	All
QSTX-V-8	Platinum Vinyl	QSTX-4-8	Gray Paint	QSTX-X-8	Beige Paint	6" to 8"	All
QSTX-V-10	Platinum Vinyl	QSTX-4-10	Gray Paint	QSTX-X-10	Beige Paint	8" to 10"	All
QSTX-V-12	Platinum Vinyl	QSTX-4-12	Gray Paint	QSTX-X-12	Beige Paint	10" to 12"	All

Optional Accessories – Additional Items as Determined by Job Specifications

Free-Blow Plenum Boxes:

QPB42-V	Platinum Vinyl	QPB42-4	Gray Paint	QPB42-X	Beige Paint	Front Supply, 4-way deflection grille	QW2S, QW3S
QPBS42-V	Platinum Vinyl	QPBS42-4	Gray Paint	QPBS42-X	Beige Paint	Same as QPB42, plus 2-way deflection grille on each side.	
QPB48-V	Platinum Vinyl	QPB48-4	Gray Paint	QPB48-X	Beige Paint	Front Supply, 4-way deflection grille	QW4S, QW5S
QPBS48-V	Platinum Vinyl	QPBS48-4	Gray Paint	QPBS48-X	Beige Paint	Same as QPB48, plus 2-way deflection grille on each side.	

Top Fill Systems for Finishing Plenum Boxes to Ceilings:

QPBX42-9-V	Platinum Vinyl	QPBX42-9-4	Gray Paint	QPBX42-9-X	Beige Paint	Use with QPB42 or QPBS42 (adjusts to ceilings up to 99")	QW2S, QW3S
QPBX42-10-V	Platinum Vinyl	QPBX42-10-4	Gray Paint	QPBX42-10-X	Beige Paint	Use with QPB42 or QPBS42 (adjusts to ceilings up to 105")	
QPBX48-9-V	Platinum Vinyl	QPBX48-9-4	Gray Paint	QPBX48-9-X	Beige Paint	Use with QPB48 or QPBS48 (adjusts to ceilings up to 99")	QW4S, QW5S
QPBX48-10-V	Platinum Vinyl	QPBX48-10-4	Gray Paint	QPBX48-10-X	Beige Paint	Use with QPB48 or QPBS48 (adjusts to ceilings up to 105")	

Cabinet Extensions for Ducted Applications:

QCX10A-V	Platinum Vinyl	QCX10A-4	Gray Paint	QCX10A-X	Beige Paint	20" height (adjusts for ceilings up to 97"; add QPBX42-9 for 97" to 10'3" finished ceiling heights)	QW2S, QW3S
QCX15A-V	Platinum Vinyl	QCX15A-4	Gray Paint	QCX15A-X	Beige Paint	20" height (adjusts for ceilings up to 97"; add QPBX48-9 for 97" to 10'3" finished ceiling heights)	QW4S, QW5S

Hot Water Coils with Plenum Boxes:

QPBHW42-F-V	Platinum Vinyl	QPBHW42-F-4	Gray Paint	QPBHW42-F-X	Beige Paint	Free blow plenum box	QW2S, QW3S
QPBHW48-F-V	Platinum Vinyl	QPBHW48-F-4	Gray Paint	QPBHW48-F-X	Beige Paint	Free blow plenum box	QW4S, QW5S
QPBHW42-D-V	Platinum Vinyl	QPBHW42-D-4	Gray Paint	QPBHW42-D-X	Beige Paint	Ducted plenum box	QW2S, QW3S
QPBHW48-D-V	Platinum Vinyl	QPBHW48-D-4	Gray Paint	QPBHW48-D-X	Beige Paint	Ducted plenum box	QW4S, QW5S

NOTE: The same top fill system and cabinet extensions can be used with hot water coil plenum boxes as with standard plenum boxes.

Double O-Ring Water Connections

IMPORTANT NOTE: All water coils are equipped with male half of double O-ring fittings and a mating half must be used. No other type of fitting will mate up. The DORFC Flow Centers also have double O-ring connections on both heat pump and loop sides of flow center.

Depending upon pump and piping options ordered, additional double O-ring fittings and hose may be required. Fittings are available for threaded, barbed, soldered and fusion connections.



Elbow, 1" MPT X Double
O-ring with 1/4" Port and
Pressure/Temperature Test Plugs
DORMP1-90



1" MPT X Double O-ring
DORMP1-S



1" FPT X Double O-ring
DORFP1-S



Elbow, 1" Hose Barb X Double
O-ring with 1/4" Port and
Pressure/Temperature Test Plugs
DORB1-90-4HC



1" Hose Barb X
Double O-ring
DORB1-S-4HC



1-1/4" Socket Fusion X
Double O-ring
DORF125-S



1" Copper Sweat X Double O-ring
with 1/4" FPT Port &
Pressure/Temperature Test Plugs
DORS1-S

Individual Double O-Ring Fitting Packs (Qty 2 per pack)

DORMP1-90	(2) 1" MPT 90° double o-ring elbows with 1/4" FPT ports and 8603-026 pressure/temperature test plugs
DORMP1-S	(2) 1" MPT straight double o-ring fittings
DORFP1-S	(2) 1" FPT straight double o-ring fittings
DORB1-90-4HC	(2) 1" barbed 90° double o-ring elbows with 1/4" FPT ports, 8603-026 pressure/temperature test plugs and (4) SS 1" hose clamps
DORB1-S-4HC	(2) 1" barbed straight double o-ring fittings with (4) 1" SS hose clamps
DORF125-S	(2) 1.25" fusion straight double o-ring fittings
DORS1-S	(2) 1" copper sweat straight double o-ring fittings with 1/4" FPT ports and 8603-026 pressure/temperature test plugs

Optional Hose

HK1-25

(1) 25' section of 1" ID 150 PSI hose

Flow Centers & Individual Pumps (See Pump Ratings Below)

Pump Option	Pump Model	No. of Pumps	Description	Installation Method
1	DORFC-1	1	Loop Flow Center w/Insulated Cabinet, 230V-60Hz-1Ph, Double O-ring Fittings, UP26-99F Pump, Brass Isolation & Flush Valves Built-In	Can be factory or field installed
2	DORFC-2	2	Loop Flow Center w/Insulated Cabinet, 230V-60Hz-1Ph, Double O-ring Fittings, UP26-99F Pump, Brass Isolation & Flush Valves Built-In	
3	UPS15-42F	1	Pump with Isolation Valves, 230V-60Hz-1Ph, Piped to Rear of Cabinet, Double O-ring Connections	Factory installed only
4	UP26-64F	1	Pump with Isolation Valves, 230V-60Hz-1Ph, Piped to Rear of Cabinet, Double O-ring Connections	
5	UPS26-99FC	1	Pump with Isolation Valves, 230V-60Hz-1Ph, Piped to Rear of Cabinet, Double O-ring Connections	



DORFC-2



UPS26

Flow Center and Individual Pump Accessories

Bard Part Number	Required Quantity	Description	Used With
QWRK	1	Consists of control relay, two 3A circuit breakers, all wiring and all installation parts	Included with factory installed DORFC Flow Centers and UPS Pumps. Order only if field installing any flow center or pump.
QWHK	1	Consists of two 1" x 33" 200 PSIG hoses with SS braided sheathing and fitted with straight double o-ring fittings one end and 90° elbow double o-ring fittings with P/T ports installed on opposite end.	Included with units for factory installed DORFC's. Order only if field installing DORFC.

① This is factory installed if flow center or pump is factory installed.

Loop Pump Modules and Individual Pump Capacities ① ②

Pump Option	Pump Model	No. of Pumps	No. of Speeds	Speed	WATER FLOW IN GPM												
					5	6	7	8	9	10	11	12	13	14	15	16	
1	DORFC-1	1	1	Single	29.5	29	28.5	28	27.5	26.5	25.5	24.5	23	22.5	22	21	
2	DORFC-2	2	1	Single	59	58	57	56	55	53	51	49	46	45	44	42	
3	UPS15-42F	1	3	High	12.1	11.5	10.7	9.7	8.8	8	—	—	—	—	—	—	
				Medium	6.8	5.7	4.5	—	—	—	—	—	—	—	—	—	—
				Low	—	—	—	—	—	—	—	—	—	—	—	—	—
4	UP26-64F	1	1	Single	21.5	21	20	19	18	17	16.5	16	15	14	13	12.5	
5	UPS26-99FC	1	3	High	29.5	29	28.5	28	27.5	26.5	25.5	24.5	23	22.5	22	21	
				Medium	23.5	22.2	21.5	20.3	19.5	18.5	17.8	16.5	15.3	14.3	13.3	12.4	
				Low	15.3	13.8	12.4	10.9	9.8	8.4	—	—	—	—	—	—	

① Pump output shown in feet head @ GPM at top of columns.

② Refer to Water Coil Pressure Drop table (Page 8) for feet head allowances for basic QW*S complete system. Additional feet head allowance from basic unit to main piping loop must be included and determined by others.

Ground Loop Service Accessories for Installations with DORFC Flow Centers

Heat Pump Model	Bard Part Number	Required Quantity	Description
		DORCL1-90	Each
	CLB1-S	Each	(2) 1" straight barbed quick-connect cam-lever female fittings to connect to DORCL1-90 fittings above
	GGK-1	Each	(1) Geo-Gooser w/shut-off valve, 0-100 PSI gauge, garden hose connection, P/T fitting 1/8" probe
	DORGHMT	Each	(1) Double o-ring x male garden hose adapter fitting for loop flow center (to burp/boost loop)



**1" Cam Lever Male X Double O-ring
DORCL1-90**



CLB1-S



**Garden Hose Male X O-ring (single) Adapter
DORGHMT**



GGK-1

This Page Intentionally Left Blank

QW*S Step Capacity Series Q-Tec™ Geothermal HP Model Nomenclature

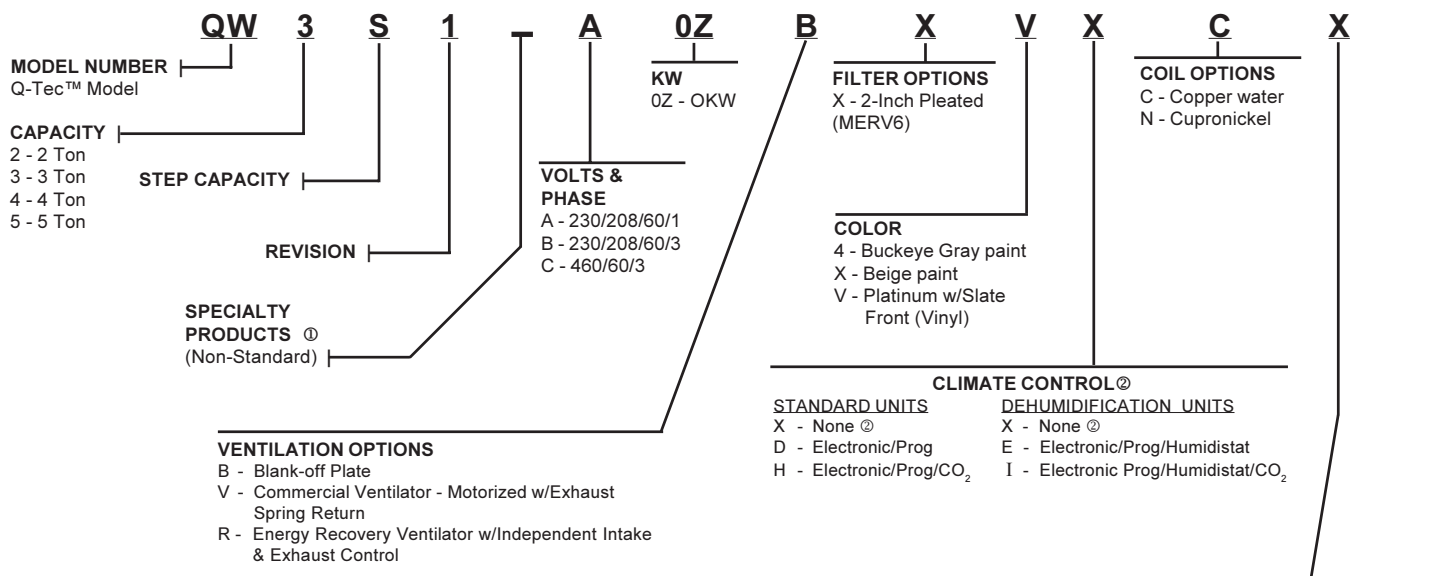

FACTORY INSTALLED PUMP & PIPING OPTIONS

- X - None; all pump & water connections field installed, requires field piping to the coaxial water coil using double o-ring fittings, which must be ordered separately.
- 1 - DORFC-1 double o-ring flow center, single Grundfos UP26-99F pump piped to water coil with 150 PSI reinforced hose
- 2 - DORFC-2 double o-ring flow center, double Grundfos UP26-99F pump piped to water coil with 150 PSI reinforced hose
- 3 - Single Grundfos UPS15-42F pump, isolation valves both ends, piped with copper to double o-ring fittings back corners of unit
- 4 - Single Grundfos UP26-64F pump, isolation valves both ends, piped with copper to double o-ring fittings back corners of unit
- 5 - Single Grundfos UPS26-99-FC pump, isolation valves both ends, piped with copper to double o-ring fittings back corners of unit

NOTE: See Page 22 for pump capacities in ft. of hd.

NOTE: ① Insert "D" for dehumidification with hot gas reheat. Reference 7960-612 for complete details.
② If "X" control option is selected, then thermostat and humidistat, if applicable, or DDC control system must be field supplied.

*See Pages 21 & 22 for Additional
Required and Optional Field Installed Accessories*

Optional Field Installed Hard Start Kits for 1-Phase Models ①

Unit Model	Field Installed Part Number
QW2S1-A only	SK111
QW3S1-A only	SK114
QW4S1-A only	SK111
QW5S1-A only	SK115

① Start Capacitor and potential relay start kit can be used with all -A single phase models only. Increases starting torque 9x. Not used on -B or -C three phase models.



Bard Manufacturing Company, Inc.
Bryan, Ohio 43506
www.bardvac.com

Due to our continuous product improvement policy, all specifications subject to change without notice.

Before purchasing this appliance, read important energy cost and efficiency information available from your retailer.

**Form No.
S3419
April, 2010**

Supersedes S3419-210.A